

Introduction

A brake pad modification has been made on 4Runner and Tacoma 4x4 models to reduce pad knocking noise. This problem usually occurs upon first pedal application after changing driving direction (i.e. forward to reverse).

Affected Vehicles

- **1997 4Runner** starting VINs
 - JT3GM84R * V0004296**
 - JT3HM84R * V0007803**
 - JT3GN86R * V0010776**
 - JT3HN86R * V0027427**
 - JT3HN87R * V0027427**

- **1997 Tacoma (4x4)** starting VIN **4TA * * * * N * VZ220360**

Modification Detail

The steel backing plate of the brake pad was widened from 119.3 mm to 119.55 mm in order to reduce the pad movement in the brake caliper.

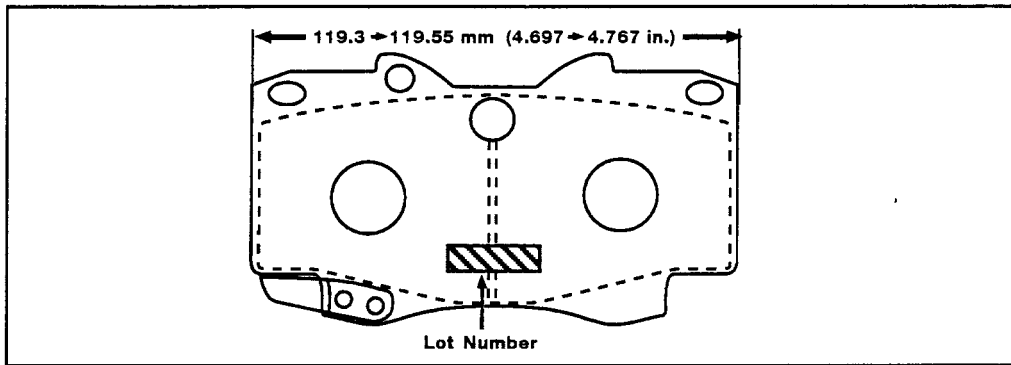

4Runner (Blue Color) –
Modified brake pads can be identified by the lot number, starting after:

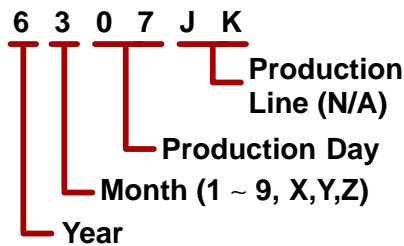

Tacoma 4x4 (Mauve Color) –
Modified brake pads can be identified by the lot number, starting after:

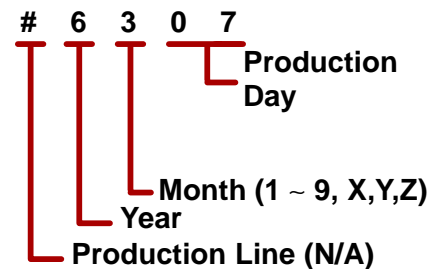

Parts Information

MODEL	PART NUMBER
4Runner	04465-35190
Tacoma (4x4)	04465-35080

Warranty
Information

OPCODE	DESCRIPTION	TIME	OPN	T1	T2
473301	R&R front disc brake pads (both sides)	0.7	04465–35190 04465–35080	91	18

- * Warrantable only for 12 months or 12,500 miles from date-of-first-use or demo date, whichever occurs first. Coverage is extended to 24 months or 18,000 miles, whichever occurs first, in the state of New York due to “Lemon Law” legislation.

NOTE:

Replacement of the front brake pad kit and/or shims is limited to correction of a problem based upon a customer’s complaint and subject to all of the provisions of Toyota Warranty Policy Bulletin POL94–18, dated October 10, 1994.